

TABLE OF CONTENTS

A. SAFETY GUIDELINES.....	1
B. INTRODUCTION.....	2
C. ASSEMBLING YOUR CYCLE	
List of parts.....	3
Step by step instructions.....	4
Floor level adjustment.....	8
D. EXERCISING ON YOUR CYCLE	
Understanding the Electronics Package.....	9
Manual.....	9
Interval.....	9
Program.....	10
Cool Down.....	10
E. KEY FUNCTIONS	
RESET.....	11
RPM.....	11
TIME.....	11
DISTANCE.....	11
CALORIE.....	11
F. Exercising With Sports Art	
How long should I exercise.....	12
How often should I exercise.....	12
G. MAINTAINING YOUR CYCLE	
Cleaning The Cycle.....	12
H. PULSE.....	13

Sports Art 506P recumbent cycle

A. SAFETY GUIDELINES:

Please read and follow the following safety guidelines:

- Read this owner's manual and follow the instructions.
- Assemble and operate the cycle on a solid, level surface.
- Always unplug the cycle from an electric socket immediately after using and before cleaning.
- Never allow children on or near the cycle.
- Check the cycle before every use. Make sure all parts are assembled, and all nuts and bolts are tightened. Do not use the cycle if the unit is disassembled in any way.
- Keep your hands away from moving parts.
- Wear proper workout clothing: do NOT wear loose clothing. Do not wear shoes with leather soles or high heels. Tie all long hair back.
- Don't rock the unit from side to side, and use care when mounting and dismounting the unit.
- Don't stand on the unit.
- Do not use any accessories that aren't specifically recommended by the manufacturer as these might cause injuries or cause the unit to fail.
- Work within your recommended exercise level, do NOT work to exhaustion.
- If you feel any pain or abnormal sensation, STOP YOUR WORKOUT and consult your physician immediately.

Caution:

Before beginning any exercise program, you should consult with your doctor. It is recommended that you undergo a complete physical examination.

B. INTRODUCTION:

Congratulations on purchasing one of the finest pieces of exercise equipment on the market today. Constructed of high quality materials and designed for years of troublefree usage, you will find the unit very easy to assemble and use.

Before using your cycle, we recommend that you familiarize yourself with this Owner's Manual. Whether you are a first time user of an exercise cycle or a seasoned "pro," understanding the correct use of the equipment will enhance your ability to achieve your exercise goals safely and successfully.

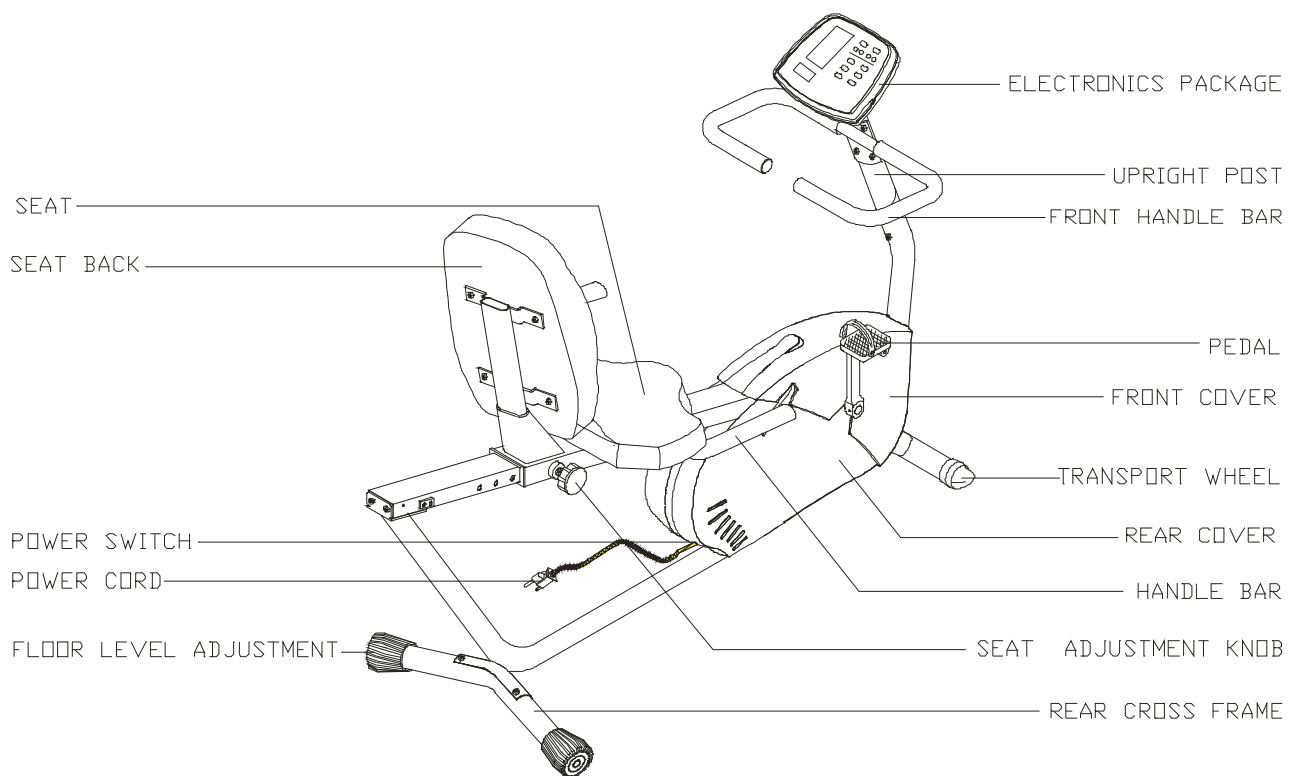

C. ASSEMBLING YOUR CYCLE:

Before assembling your cycle, please make sure you have all the following items.

If any items are missing, contact your authorized Sports Art dealer.

List of parts:

- Four (4) sets of 5/16" bolts and washers - - Upright post and cycle main frame
- Four (4) sets of 5/16" bolts and washers - - Rear cross frame and cycle main frame
- Four (4) sets of 5/16 bolts, spring washers and flat washers - - Handlebar and cycle main frame
- Four (4) sets of 5/16" bolts and washers - - Seat back frame and cycle main frame
- Four (4) sets of M6 - - Seat back and seat back frame
- Four (4) sets of M6 - - Seat base and handlebar
- Four (4) sets of 5/16 bolts and washers - - Upright post and front handlebar
- One pair of foot pedals
- One hex allen wrench
- One combination wrench

IMPORTANT: The packaging for this bike was designed to protect it during shipment. Please store the original packaging in a safe place in case you need to ship the unit in the future.

Step by step instructions

Before assembling your cycle, make sure that you have all the above parts. The following steps explain how to assemble your exercise cycle. Please read every step thoroughly, and follow the directions completely to ensure correct assembly.

1. Make sure all packing materials are removed from the cycle frame.
2. Place the cycle on a level, flat surface.
3. Please assemble the upright post to the bicycle main frame, using the four (4) screws and washers provided. Tighten the bolts securely (see Fig. 1).

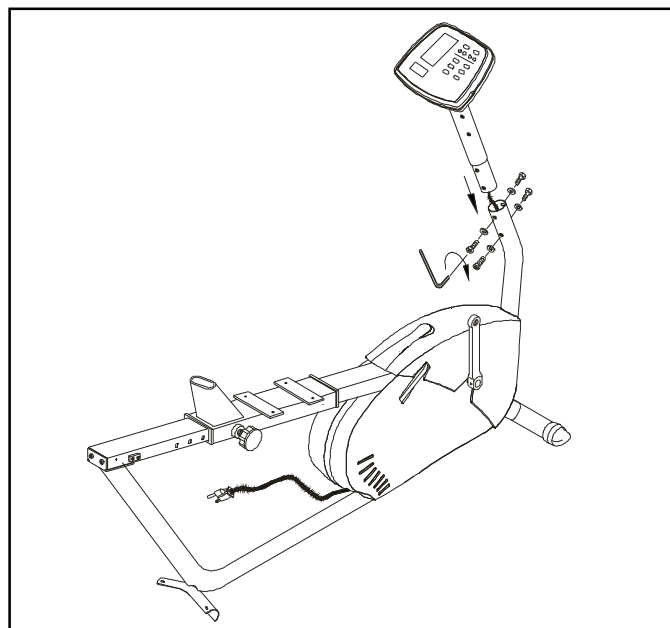

Fig.1

4. Please assemble the rear cross frame to the main bike frame using the four (4) screws and washers provided. Make sure that the front and rear legs sit stably on the floor before you tighten the bolts securely (See Fig. 2).

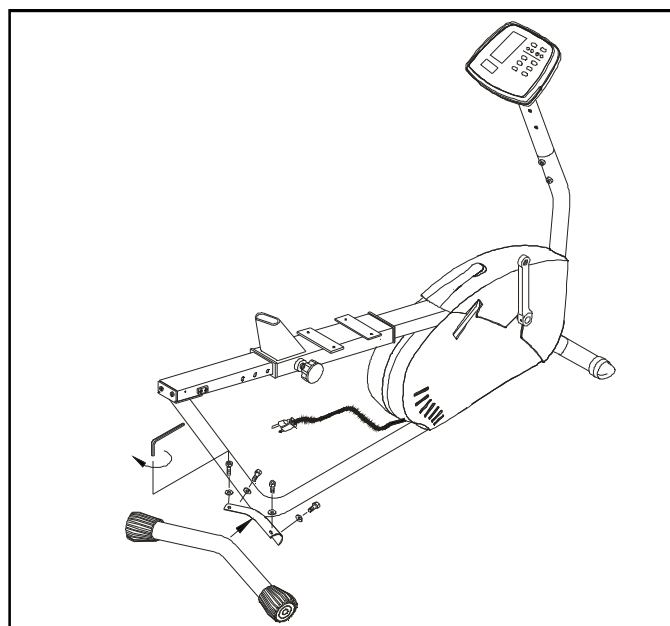

Fig.2

5. Please attach the handlebar mounting plate to the cycle frame, using four (4) bolts, spring washers and flat washers. Tighten the bolts securely (See Fig. 3).

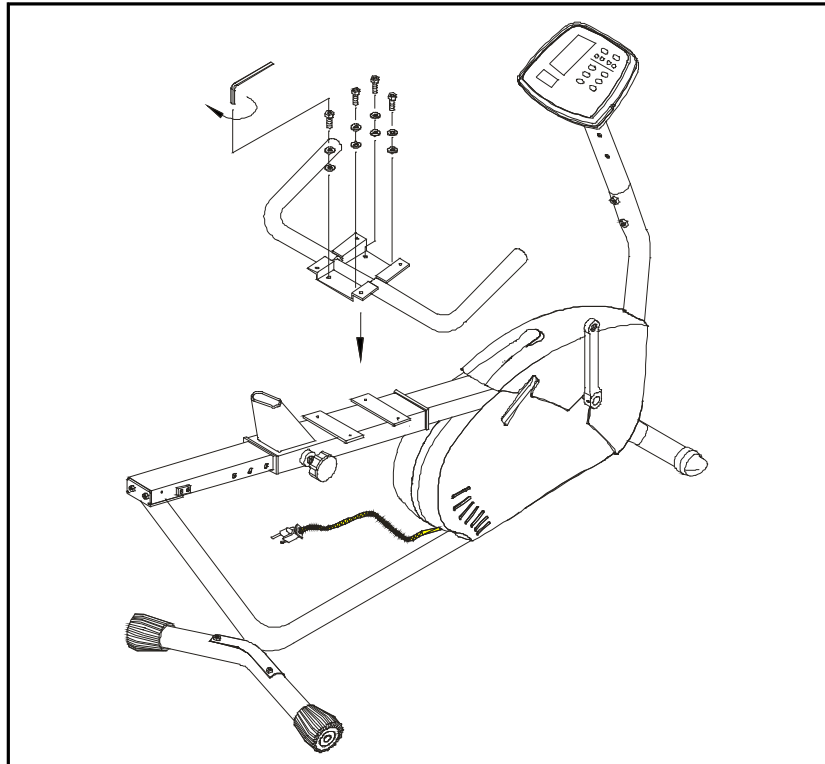

Fig.3

6. Please insert the seat back frame assembly into the handlebar mounting plate and tighten securely by using the four (4) bolts and washers provided. (See Fig. 4)

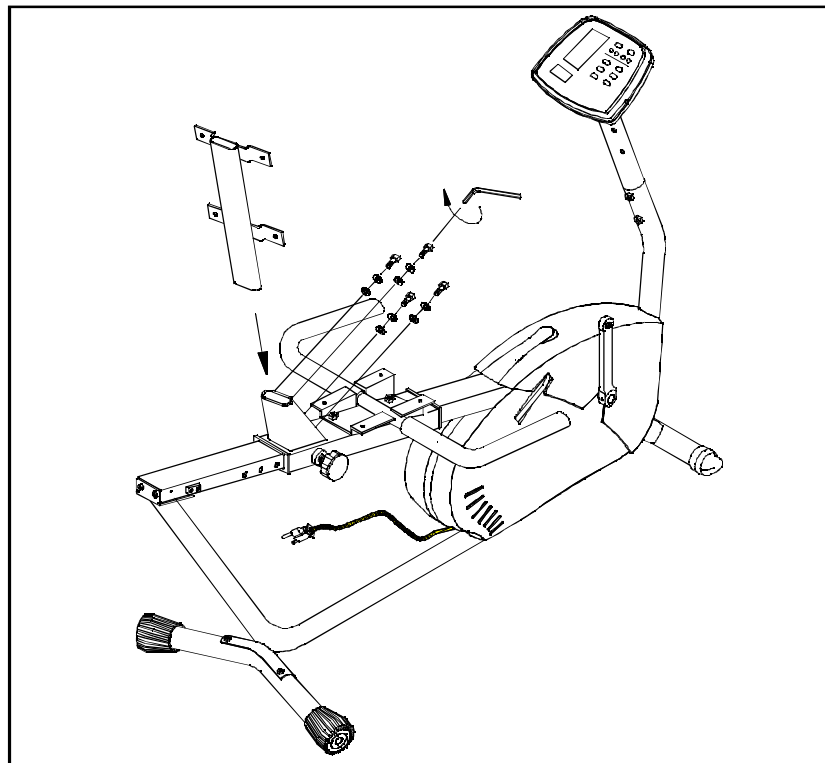

Fig.4

6.1 Please attach the seat back to the seat back frame by using the four (4) bolts and washers provided. Tighten the bolts securely (See Fig. 4.1).

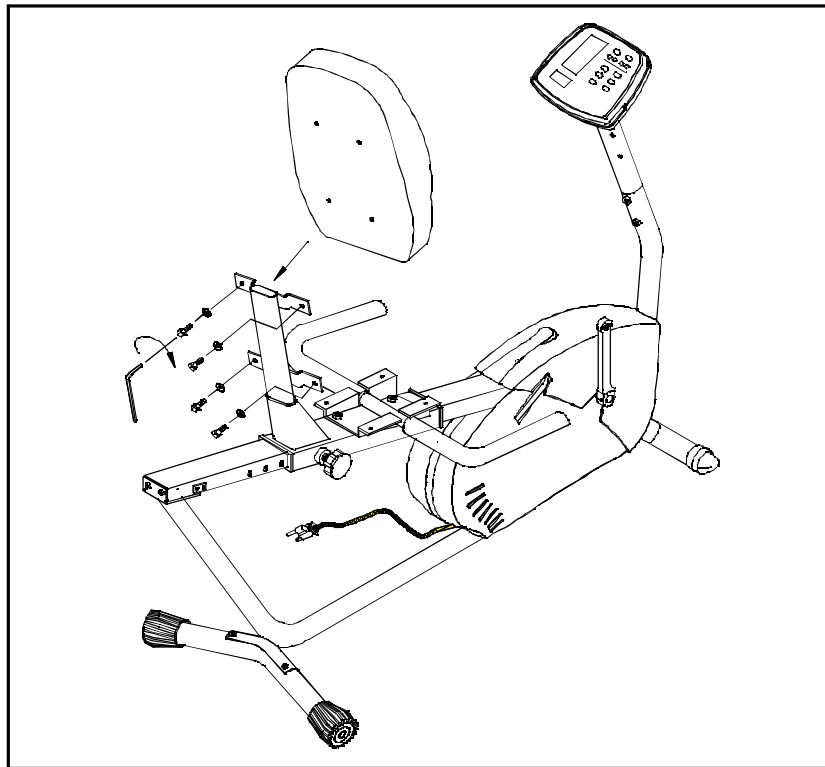

Fig.4-1

7. Please attach the seat base to the handlebar mounting plate by using the four (4) bolts and washers provided. Insert the bolts from underneath the seat - two in back and two in front, through the handlebar mounting plate. Tighten the bolts securely (See Fig. 5).

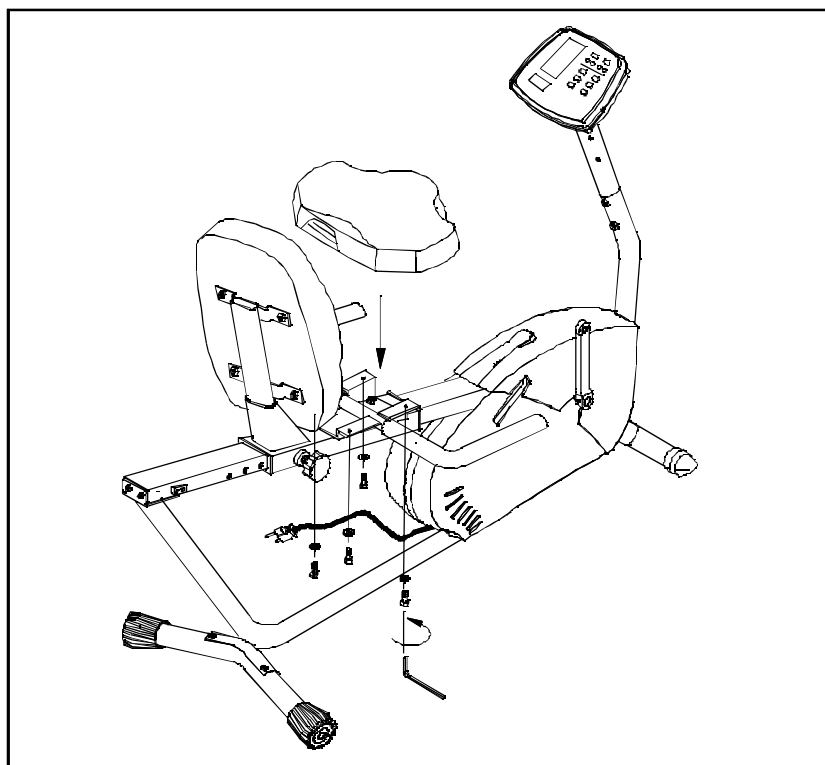

Fig.5

8. Please attach the foot pedals to the crank arms on the cycle using the wrench provided. Be careful to install the pedals on the correct crank arm. A "R" or "L" on the foot pedal indicates the correct side. Install the pedal marked "R" on the right-hand crank arm (as you stand at the rear of the cycle facing front). When you install the pedal on the left hand crank arm, rotate the pedal counterclockwise to tighten since the pedal has left-hand screw threads. Tighten the pedals securely. (See Fig. 6)

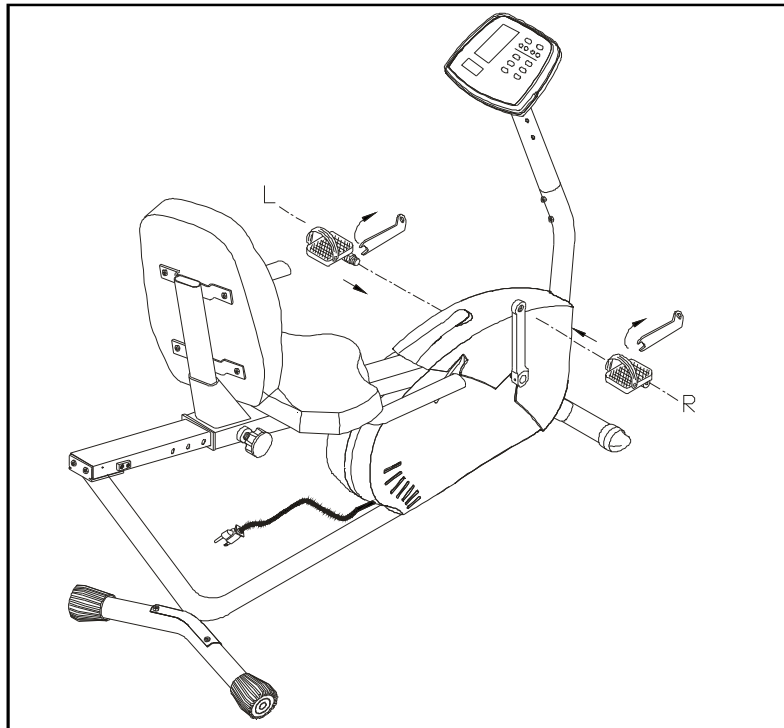

Fig.6

9. Please assemble the handlebar to the upright post using the four (4) screws and washers provided. Tighten the bolts securely (See Fig. 7).

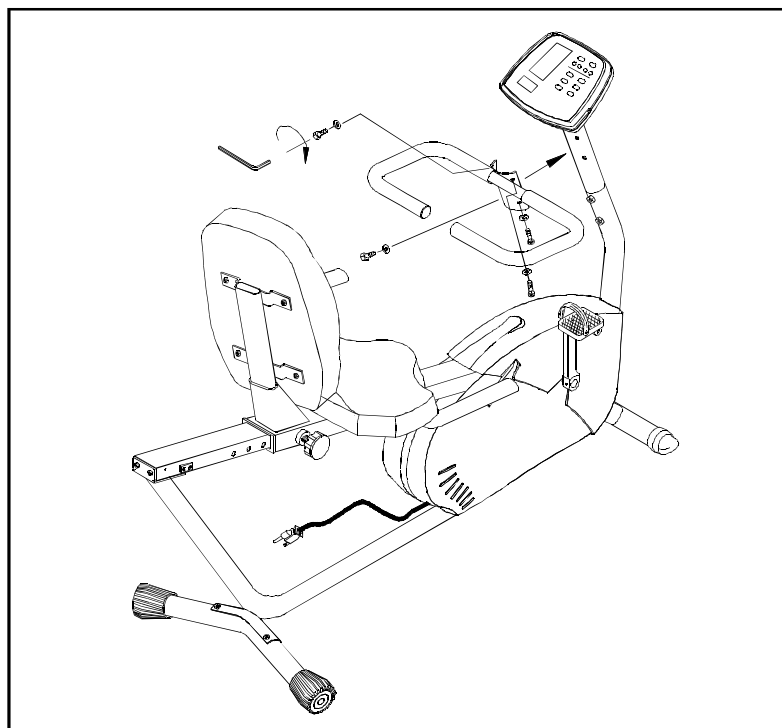

Fig.7

Floor level adjustment

10. Please check to make sure all the bolts are tightened securely. If your Sports Art 506P cycle is unsteady on the floor, turn the right or left wheels of the rear leg either to make the cycle sitting stable. (See Fig. 8)

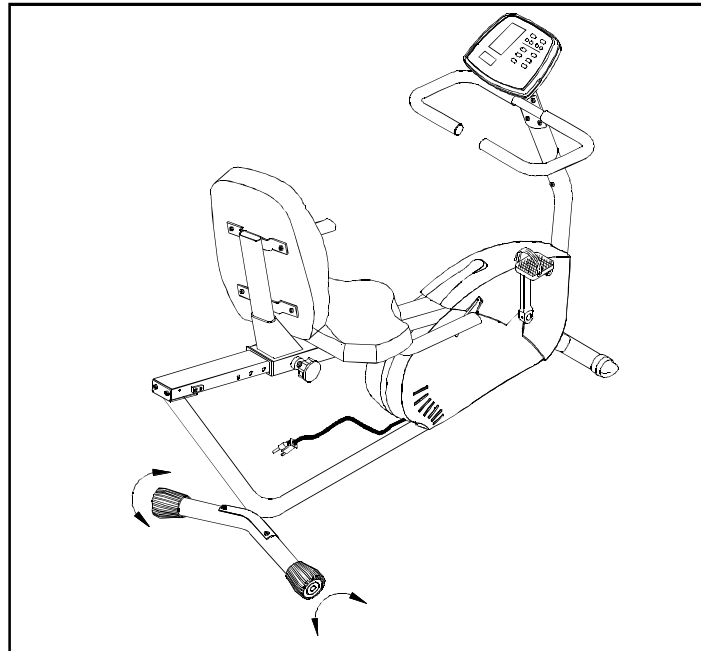

Fig.8

Seat Adjustment

11. Seat Adjustment: Sit on the cycle with both feet in the pedals and one leg extended as far as is comfortable (do not straighten your leg - - there should be some bend in it when you pedal), turn the seat adjustment knob (located under the seat) counterclockwise to release it and move the seat forward or backward until the pedal distance is comfortable. Twist the knob clockwise to tighten (See Fig. 9).

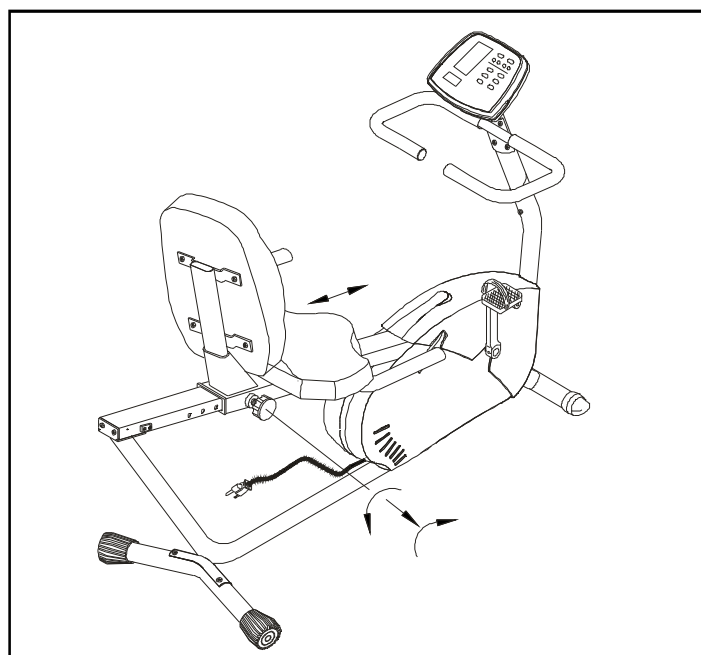

Fig.9

Your 506P recumbent cycle is assembled and ready to use.

D. EXERCISING ON YOUR CYCLE:

Understanding the Electronics Package

1. When you turn the unit on, the electronics package will display "USER 0". The unit begins with "LEVEL 1." If this is where you want to start, simply press ENTER and begin pedaling the bike.
2. The Sports Art 506P has 20 tension levels, with LEVEL 1 being the easiest, and LEVEL 20 being the hardest. To change levels at any time during your workout, simply press the ▼▲keys to switch to your desired tension level.
3. The Sports Art 506P has five users (Users 0 - 4), and the electronics package will hold the User data you enter into it (not for User 0). To enter USER information, press the USER key for the USER number you prefer.

MANUAL

1. Press the MANUAL key, and one level line will appear in the display. In the MANUAL Mode, you can set one of the following: TIME, DISTANCE or CALORIES (but not more than one). Press the MODE key to select one of the three, then use the ▼▲keys to set your desired workout length, distance or calories burned, then press ENTER.
2. After you have set the above, begin to pedal and your workout information will be retained and applied to your workout. If you stop pedaling, the package will display PEDAL to remind you. If you do not begin to pedal within three minutes, the electronics package will automatically RESET.
3. The electronics package will automatically count down from your desired setting, BEEP when your workout is finished, and begin the COOL DOWN period.

If you want to repeat your workout, just press ENTER and continue pedaling.

INTERVAL:

1. The Interval Workout Mode allows you to design your own personalized workout program. You specify the tension and duration for eight workout segments, then the 506P will cycle through these until your desired time is reached.
2. Press the INTERVAL key, and the electronics package will display SEG 1. For SEG 1, just press ENTER separately after you select your desired time and tension. Then SEG 2 will appear in the LCD display, allowing you to choose the desired tension and time for more segments.
3. For Segments 2-8, please refer to the instructions above. Once all segments are set, press ENTER at a time, and your own personalized program will be recorded. If you only want to set four segments, for instance, leave segments 5-8 with values of zero, and the bike will use only your desired four segments.

4. While you are using the INTERVAL program, you may change the tension by pressing the ▼▲keys any time during your workout.
5. After you have set the above, begin to pedal and your information will be retained and applied to your workout. If you do not begin to pedal within three minutes, the electronics package will automatically RESET.

In addition, if you need to interrupt your workout (to change CDs, the TV channel, answer the phone, etc.), simply stop pedaling. The electronics package will display PEDAL and pause your workout. Keep in mind that if you do not start pedaling again within three minutes, the electronics package will automatically RESET.

6. The electronics package will automatically count down from your desired setting, BEEP when your workout is finished, and begin the COOL DOWN period.

If you want to repeat your workout, just press ENTER and continue pedaling.

PROGRAM

The 506P features a total of four (4) professionally designed workout programs. The programs control the tension of the bike. At any point during the program workout, you can change the tension by using the ▼▲keys.

Press the PROGRAM key to scroll between the four programs. When you have chosen the Program you want, press the ENTER key. You will be prompted to input TIME, DIS or CALORIES. Use the MODE key to switch between CALORIES, DIS and TIME, then use the ▼▲keys to select your desired calorie expenditure, distance or time, then press ENTER.

In addition, if you need to interrupt your workout (to change the TV channel, answer the phone, etc.), simply stop pedaling. The electronics package will display PEDAL and pause your workout. Keep in mind that if you do not start pedaling again within three minutes, the electronics package will automatically RESET. When you begin pedaling again (within three minutes), you will pick up right where you left off.

During these programs, the unit will automatically switch between levels, giving you the feeling of riding on hills or level ground.



COOL DOWN

1. When you have reached your desired time or distance, the electronics package will beep to remind you that your workout period is over, and the COOL DOWN period is beginning.

2. When your workout is over, you will be prompted to perform a COOL DOWN. This COOL DOWN portion will decrease the tension you are using by half and decrease one level every three seconds until you get to level one, when the COOL DOWN period will be over.

E. KEY FUNCTIONS

RESET: Press this key and the electronics will go back to the prior workout entered. If this is the workout you prefer, press ENTER.

RPM: This displays the revolutions per minute.

TIME: Press the ▼▲ keys to set your desired workout time. Every press of the key will change the value by one minute. Pressing and holding it will change the value by five minutes every half second. After you have set your desired time, press ENTER. The unit will count down from this value, beep when the value is reached, then prompt you to COOL DOWN.

DISTANCE: Press the ▼▲ keys to set your desired workout distance. Every press of the key will change the value by 0.1. Pressing and holding it will change the value by 1 every half second. After you have set your desired distance, press ENTER. The unit will count down from this value, beep when the value is reached, then prompt you to COOL DOWN.

CALORIE: Press the ▼▲ keys to set your desired workout caloric expenditure. Every press of the key will change the value by 1 K. Pressing and holding it will change the value by 5 K every half second. After you have set your desired caloric expenditure, press ENTER. The unit will count down from this value, beep when the value is reached, then prompt you to COOL DOWN.

You can base your workout on total TIME, total DISTANCE or total CALORIES, but not all of them. If you choose TIME, the DISTANCE and CALORIES will automatically zero. If you choose DISTANCE, the TIME and CALORIES will automatically zero. If you choose CALORIES, the TIME and DISTANCE will automatically zero.

F. Exercising With Sports Art

How long should I exercise?

The duration of your exercise session is dependent on your fitness level. In general, it is recommended that you maintain your heart rate in the training zone for at least 10 minutes to realize an aerobic benefit. As your fitness level increases, you will be able to maintain your heart rate in the training zone for longer periods: usually between 20 and 30 minutes.

When first starting your workout, use the first several minutes to warm up, then slowly increase your workload to bring your heart rate into your specific training zone. At the end of your workout, gradually decrease your workload, then exercise lightly as a "cool down".

How often should I exercise?

Aerobic exercises, to achieve the greatest benefits, should be performed 3-5 times a week. It is important to allow sufficient time, at least 24 hours, for your body to recover after exercise.

G. MAINTAINING YOUR CYCLE

This cycle requires little maintenance. The cycle's low friction operation is dependent on keeping the unit as clean as possible. See "Cleaning the cycle" for more information.

Cleaning The Cycle

CAUTION: Turn off unit and disconnect AC cord before cleaning.

Regular cleaning is recommended to keep your cycle at peak performance.

Before your workout, use a dry cloth to clean the surface of the electronics package.

Note: Never pour liquids on the electronics package. Should water, for some reason, get on the electronics package, immediately blow dry the electronics package.

To clean the plastic parts, use a mild detergent and make sure the unit is completely dry before operating.

It is recommended that you keep all liquids away from the unit during operation. Spillage of liquids onto or into the machine will void the warranty.

Should you get any problems with your cycle, such as no tension while pedaling, the display has no "RPM" reading while you are pedaling, please contact your dealer for more details.

H. PULSE

PLEASE FOLLOW THE INSTRUCTIONS BELOW IF YOUR CYCLE IS EQUIPPED WITH EARLOBE PULSE. US MODELS ARE NOT EQUIPPED WITH THIS FEATURE.

1. Press the MANUAL/HRC control key until "HRC" appears in the display.

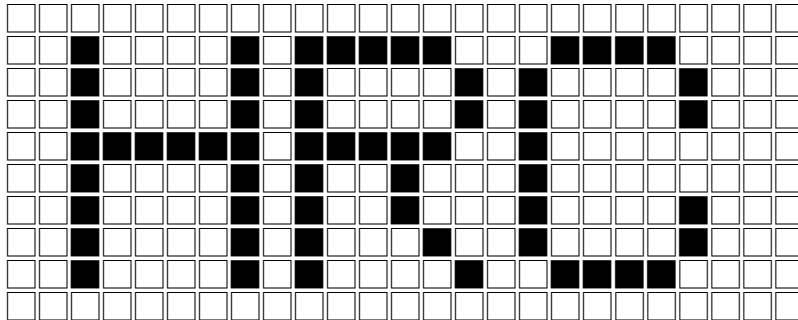

If exceed 7 seconds without pressing "ENTER", the LCD displays "ENTER" to remind user. (Flickering every second)

2. Press "ENTER" to select Heart Rate Control. Press ▼▲ keys to select FAT or CARDIO.

If exceed 7 seconds without pressing ▼▲ keys or "ENTER", the LCD displays "▼▲" "ENTER" to remind user. (Flickering every second)

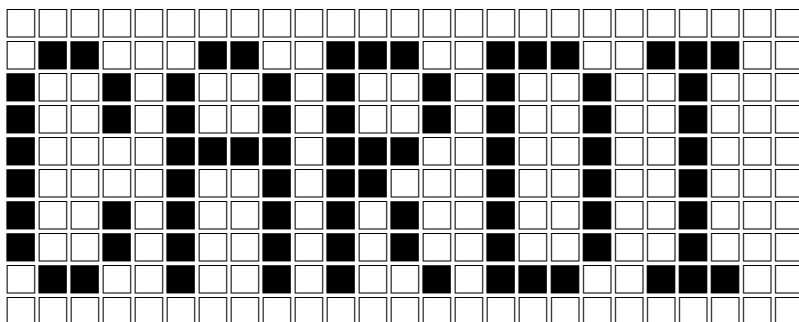
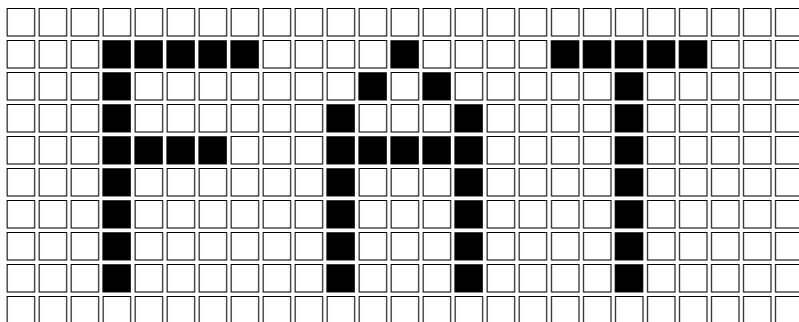

3. Press "ENTER", "AGE 35" will shows on the screen. Press either ▼ or ▲ to set your age (age range: 10 ~ 99 years old), then press ENTER to record your choice.

If exceed 7 seconds without pressing ▼▲ or "ENTER" keys , the LCD will display "▼▲" "ENTER" to remind user. (Flickering every second)

- Press "ENTER" and "TIME" displays on the screen. Then press ▼ or ▲ to set time. (Time range: 5:00~99:00 minutes). Press ▲ once to add one minute and press ▼ once to deduct one minute. If you hold down the keys, the numbers will be increased or decreased by five minutes every 0.5 seconds. Then press ENTER to record.
- Press "ENTER" and then you have the option of modifying your heart rate limit. "MDFY" will appear in the display. The LCD window will show your prescribed pulse. You can lower or higher your prescribed heart rate limit by pressing ▼ or ▲ keys. (The heart rate figures input cannot lower than the minimum or higher than maximum of prescribed limit.)

If exceed 7 seconds without pressing ▼▲ or "ENTER" keys, the LCD will display "▼▲" "ENTER" to remind user. (Flickering every second)

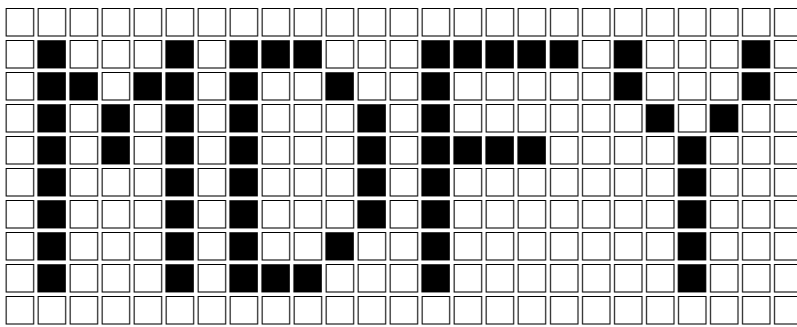

- Press "ENTER", your "HEART RATE CONTROL" program will begin. The program starts from Level 5 tension and the set heart rate will be displayed on LCD as shown below. The real heart rate will display on the screen "PULSE".

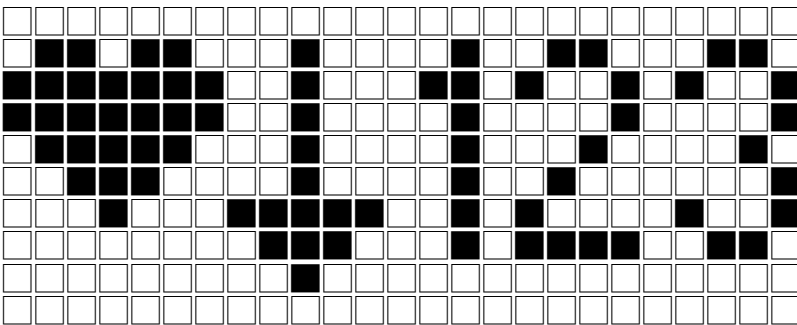

- The user begins pedaling the cycle; the time will begin to count up.

If you do not reach the speed indicators (bottom LCD) to the allowed point for over 25 seconds, the display will prompt the "SPEED UP" as below. (Flickering every second)

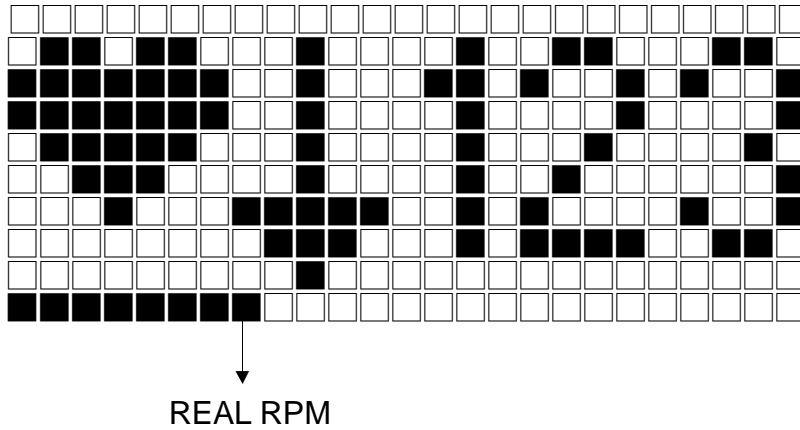

8. When the real heart rate exceeds the prescribed figures, you will get in "HEART RATE CONTROL" program and hear 6 beeping sound. The Time Display will begin to count down from the time in Target Zone you chose.
9. The HRC program will be terminated once the time in Target Zone counts down to zero. The Cool Down portion of the program is then activated. (The workout load will be reduced to half and deducted one level by every 3 seconds until to level one.) When the Cool Down period is over, the display will show "HRC".
10. If the user does not begin pedaling, "PEDAL" will flicker in the display to remind user.
11. When you are in HRC mode. If the computer can not catch your heart rate within 4 seconds, LCD will show the figures as below.

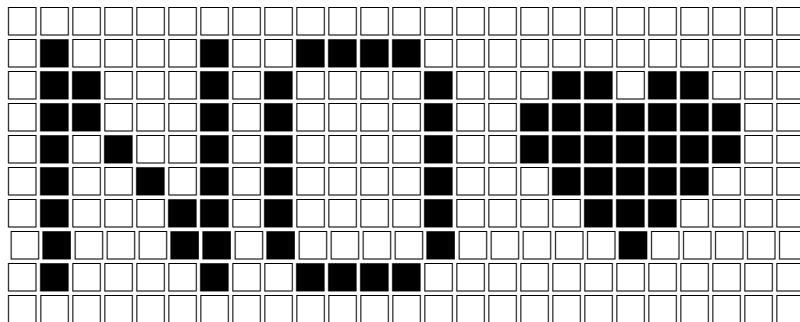
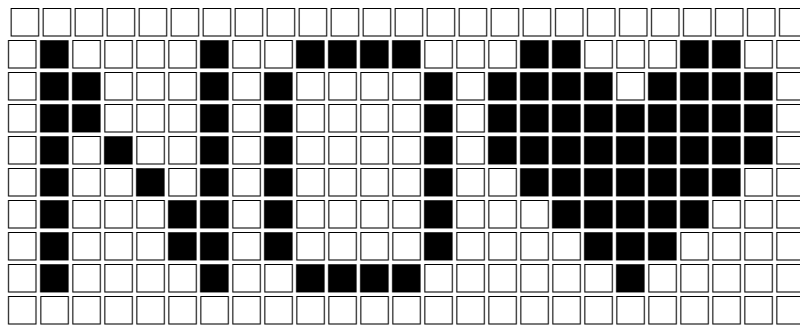

REMARKS:

1. If you use earlobe pulse to measure heart rate, you have to make sure you plug securely.
2. If you press "RESET" during the workout, "HRC" will appear on LCD immediately.
3. The AGE and TIME of User 1 ~ 4 input will be retained.

Wiring Schematic:

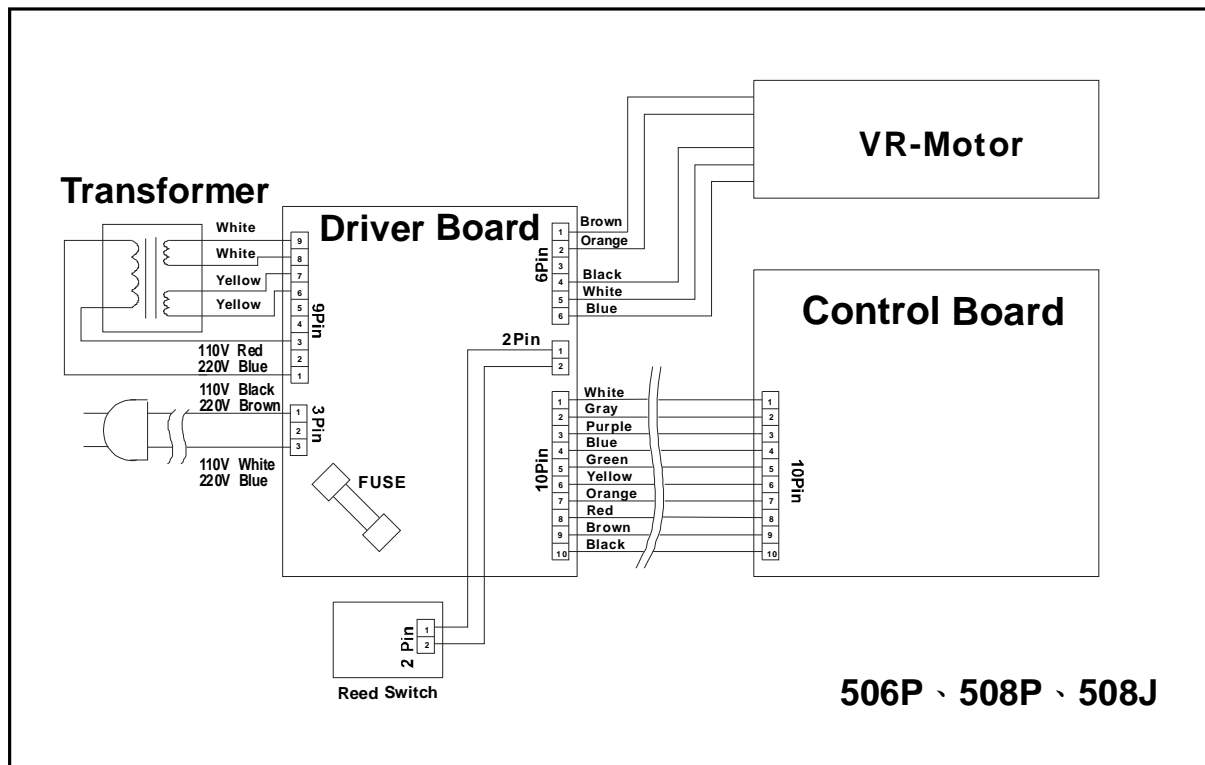

Your Authorized SPORTS ART Distributor